

T2001-MH20
4/6/2011

TO
ROOT PROBLEMS

T2001-MH20
14:01

Collections System

Asset Management Project

Who we are:

- Potable water for 62,000 people.
300 Miles of Pipe
- Recycled water across two counties. 60 miles of pipe
- Wastewater collection and treatment for 141,000 people.
 - 200 miles Sewer Pipe

FT 212.7

T2001-MH00
4/6/2011

TO
ROOT PROBLEMS

T2001-MH00
14:01

Collections System Asset Management Project

Goal: Institutionalize

3 Functions

- Provide Operations with Maintenance Management tools
- Provide Finance with Replacement Funding Estimates
- Provide Engineering with project identification

FT 212.7

INPUT

Manhole
Inspection

CCTV
Inspection

Pipe Age &
Specifications

SSO
Reporting

Pipeline
Hydro cleaning

STORAGE

Lucity

GIS

OUTPUT

Hydro
Cleaning
Schedule

CCTV
Inspection
Schedule

Data Integrity
For pipe
specifications

Preventative
& Corrective
Work Orders

Replacement
Costs

CIP Projects

Performance
Metrics

Web Based
CMMS
Application

Web Based
GIS
Application

Crystal
Reports

Critical
Assets

T2001-MH00
4/6/2006

INPUT

T2001-MH00
14:01

Manhole
Inspection

CCTV
Inspection

Pipe Age &
Specifications

SSO
Reporting

Pipeline
Hydro cleaning

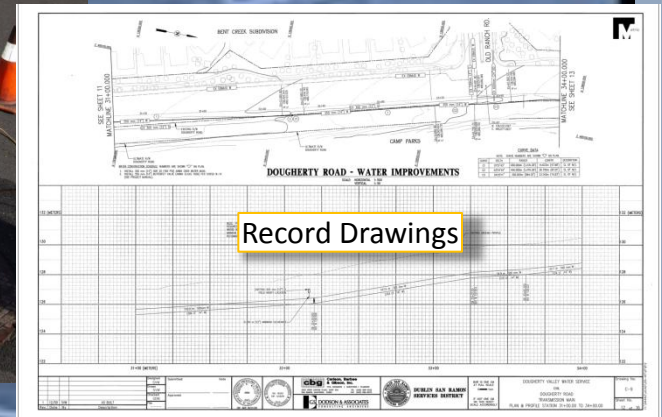

INPUT

Manhole
Inspection

CCTV
Inspection

Pipe Age &
Specifications

SSO
Reporting

Pipeline
Hydro cleaning



STORAGE

Lucity

GIS

OUTPUT

Hydro
Cleaning
Schedule

CCTV
Inspection
Schedule

Data Integrity
For pipe
specifications

Preventative
& Corrective
Work Orders

Replacement
Costs

CIP Projects

Performance
Metrics

Web Based
CMMS
Application

Web Based
GIS
Application

Crystal
Reports

Critical
Assets

GIS Master Series 7.1 - DSRSDGISUserTest

System General Users Configuration Water Backup Gps Inventory Equipment Facility S&M Waste High Inventory Data Manager User Window DBA

Overview Rec # 5 Alt ID 123 Status 1 1 Show/Hide Reported Confirmed

Info Rec# | Investigation | Cleanup | Affected Assets | Affected Assets 2 | Review | Notification | Res/AV | Custom | Custom 1 | Comments

Microsoft SQL Server Management Studio

File Edit View Query Project Debug Tools Window Community Help

New Query

Execute

CONNECT Explorer

Connect SQL Server 10.50.1600 - DSRSD(johnson)

Server Explorer

- Server
- Security
- Server Objects
- Replication
- Management
- SQL Server Agent

Object Explorer

High Potential...D.johnson (53) | SQLQuery1.sql...johnson(19) |

USE [Gbasever]

```

select NT_USMAN as UpstreamMH
      , nt_dsmn as DownstreamMH
      , NT_DIA as Diameter
      , NT_MAT_TY as Material
      , NT_Length as Length
      , NT_User17CD as [Highest Condition Rating]
      , datepart (yyyy, NT_REPL_DT) as [Install Date]
      , (datepart (yyyy, NT_REPL_DT) - (datepart (yyyy, getdate()))) as [Effective Remaining Life(yrs)]
      , datepart (yyyy, NT_REPL_DT) as [Replacement Date]
      , round (convert (money, NT_RVALUE) , 2, 1) as [Replacement Value]
      , NT_USER12 as POP
      , NT_User4 as COF
      , NT_CRITICAL as Risk
from #wvnet
where NT_REPL_DT is not null
order by NT_REPL_DT asc

```

Results Messages

	UpstreamMH	DownstreamMH	Diameter	Material	Length	Highest Condition Rating	Install Date	Effective Remaining Life(yrs)	Replacement Date
1	V17C1-32	V17C1-31	8	PVC	161.460862858427	5	1991	2	2013
2	V19A2-6	V19A2-5	10	PVC	362.674905963634	5	1965	2	2013
3	U17C3-11	U17C3-8	8	VCP-Vertiled Clay Pipe	272.25321525364	5	1972	4	2015
4	U18D2-5	U18D2-3	8	VCP	372.567962673225	5	1964	4	2015
5	V19A1-23	V19A1-22	8	VCP-Vertiled Clay Pipe	249.276305467921	5	1965	4	2015
6	T18D1-21	T18D1-20	8	VCP-Vertiled Clay Pipe	83.1575893678573	5	1986	4	2015
7	U20C1-30	U20C1-29	8	VCP-Vertiled Clay Pipe	161.092146230448	5	1981	4	2015
8	T16D1-19	T16D1-18	6	VCP-Vertiled Clay Pipe	108.687732712377	5	1969	4	2015
9	T20D1-1	U20C2-14	8	VCP-Vertiled Clay Pipe	284.990287806574	5	1965	4	2015
10	U20C1-18	U20C1-17	8	VCP-Vertiled Clay Pipe	167.601146427187	5	1981	4	2015
11	U19A1-4	U19A1-3	8	VCP	268.33754445064	5	1979	4	2015
12	U19C4-2	U19C4-1	12	VCP	161.526493927874	5	1960	4	2015
13	U17C3-25	U17C3-23	8	VCP-Vertiled Clay Pipe	506.711327856726	5	1969	4	2015
14	T16D1-35	T16D1-24	6	VCP-Vertiled Clay Pipe	145.137304891606	5	1969	4	2015
15	T16D1-30	T16D1-27	8	VCP	461.464138750099	5	1969	4	2015
16	T16D3-19	T16D3-18	8	VCP-Vertiled Clay Pipe	515.750235259166	5	1969	4	2015
17	T17D1-29	T17D1-26	6	VCP-Vertiled Clay Pipe	165.259056267229	5	1969	4	2015
18	U17C1-27	U17C1-24	8	VCP-Vertiled Clay Pipe	226.609616743744	5	1965	4	2015
19	U17C1-28	U17C1-27	8	VCP-Vertiled Clay Pipe	351.314675958736	5	1965	4	2015
20	U18C3-14	U18C3-13	8	VCP-Vertiled Clay Pipe	193.959738417798	5	1965	4	2015

Query executed successfully. TFS (10.50 RTH) DSRSD(johnson (53) Gbasever 00:00:00 4942 rows

Ln 18 Col 14 Ch 14 INS

Lucity

T-SQL

GIS

```

USE [Gbasever]
GO

/***** Object: UserDefinedFunction [dbo].[GetCOF]    Script Date: 07/06/2011 13:23:43 *****/
SET ANSI_NULLS ON
GO

SET QUOTED_IDENTIFIER ON
GO

-- Create function
--drop function getCof
create FUNCTION [dbo].[GetCOF] (@NT_DIA float, @NT_RVALUE float)
RETURNS float
WITH EXECUTE AS CALLER
AS
BEGIN
declare @Tempvalue float;
set @Tempvalue =
(
(dbo.GetReplacementCostWeight (@NT_RVALUE)) * 4)
+
(dbo.GetSocialImpactWeight (@NT_DIA) * 4)
+
(dbo.GetEnvironmentalImpactWeight (@NT_DIA) * 5)
)
return (@Tempvalue);
END;
GO

```



FT 212.7

T2001-MH00
4/6/00

T2001-MH00
14:01

INPUT



STORAGE

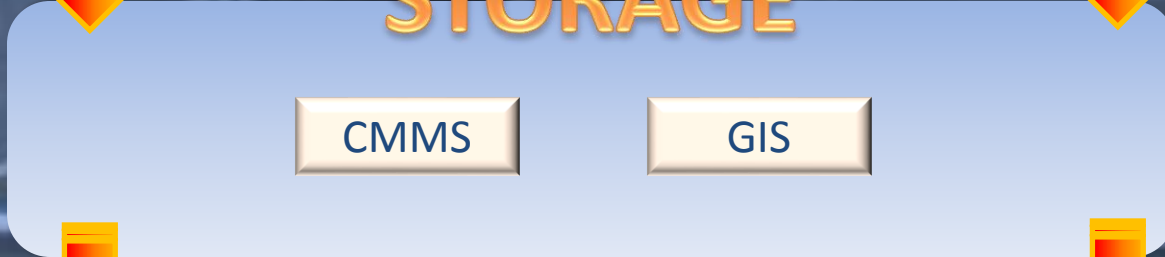

OUTPUT



T2001-MH00
4/6/2011

TO
ROOT PROBLEMS

T2001-MH00
14:01

Collections System Asset Management Project

Provide Operations with
Maintenance
Management tools

FT 212.7

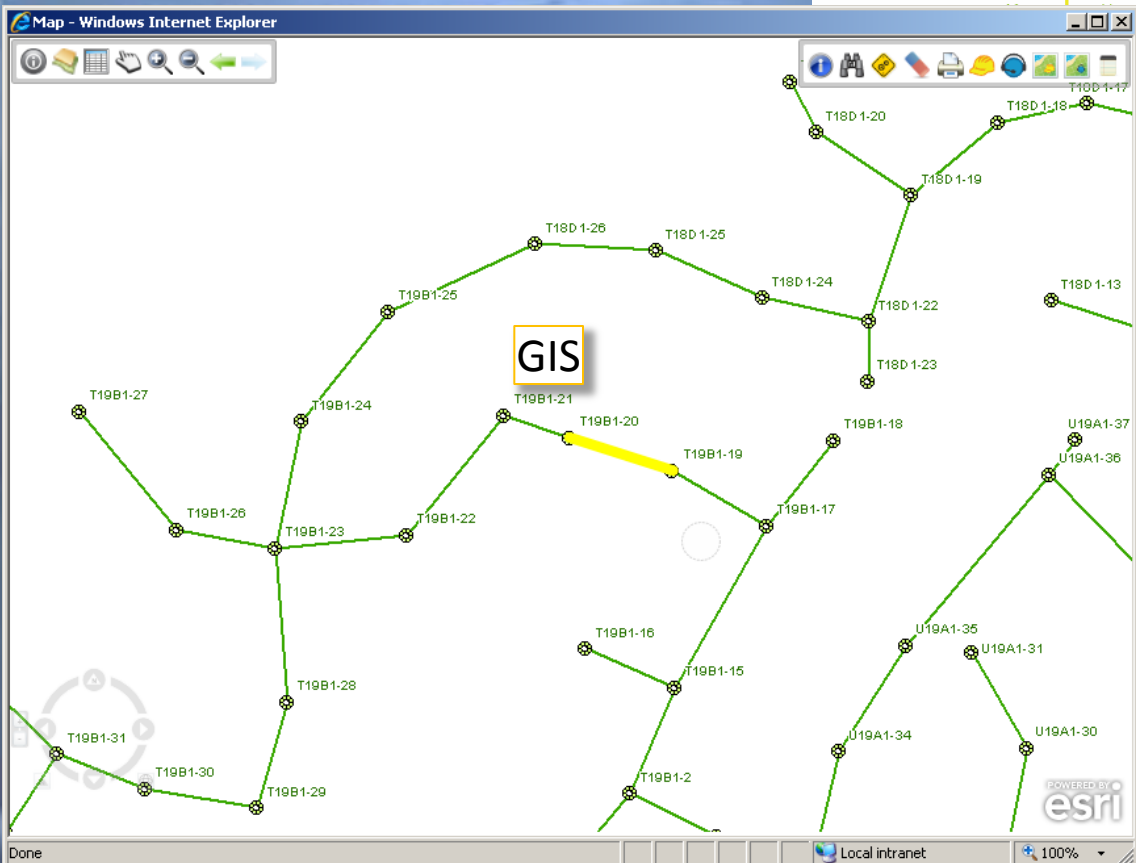

Lucity WEB

6 Year Overview Report
 Schedule Report
 Complete / Incomplete
 Reports User Manual
 Item Critical Asset Information

request (0)

Item PACP Inspection O&M Defects

Greater than 2 (32)

(46)

ns (20)

ns (6)

Item PACP Structural Defects

(6)

ervations (9)

s (8)

POWERED BY esri

OUTPUT

Hydro Cleaning Schedule	CCTV Inspection Schedule	Data Integrity For pipe specifications	Preventative & Corrective Work Orders	Replacement Costs	CIP Projects	Performance Metrics
Web Based CMMS Application		Web Based GIS Application		Crystal Reports	Critical Assets	

Year: 2012

**Hydro Cleaning Schedule
Dublin San Ramon Services District**

Page: 3

7/6/2011 11:08:08AM

Hydro Freq Yrs: 2		Tot Len: 188.12	
ID: 350	BASIN:T16D3 US: T16D3-3 DS: T16D3-2 RISK: 9 DIA: 8 MAT: VCP-Vetrified Clay Pipe	HYDRO YR: 2012	
ID: 344	BASIN:T16D3 US: T16D3-13 DS: T16D3-7 RISK: 8 DIA: 8 MAT: VCP-Vetrified Clay Pipe	HYDRO YR: 2012	
ID: 1690	BASIN:T16D3 US: T16D3-2 DS: T16D3-1 RISK: 15 DIA: 15 MAT: VCP-Vetrified Clay Pipe	HYDRO YR: 2012	
ID: 1694	BASIN:T16D3 US: T16D3-15 DS: T16D3-14 RISK: 8 DIA: 8 MAT: VCP-Vetrified Clay Pipe	HYDRO YR: 2012	
ID: 2927	BASIN:T16D3 US: T16D4-1 DS: T16D3-9 RISK: 11 DIA: 10 MAT: VCP-Vetrified Clay Pipe	HYDRO YR: 2012	
Hydro Freq Yrs: 3		Tot Len: 1,174.40	
Basin: T16D3	Tot Len: 1,878.28		
ID: 1699	BASIN:T16D4 US: T16D4-8	HYDRO YR: 2012	
ID: 1595	BASIN:T16D4 US: T16D4-14	HYDRO YR: 2012	
Hydro Freq Yrs: 1		Tot Len: 218.53	
ID: 1701	BASIN:T16D4 US: T16D4-15 DS: T16D4-2 RISK: 13 DIA: 8 MAT: VCP	HYDRO YR: 2012	
ID: 1697	BASIN:T16D4 US: T16D4-2 DS: T16D4-1 RISK: 13 DIA: 8 MAT: VCP-Vetrified Clay Pipe	HYDRO YR: 2012	
ID: 1698	BASIN:T16D4 US: T16D4-4 DS: T16D4-3 RISK: 13 DIA: 8 MAT: VCP	HYDRO YR: 2012	
ID: 590	BASIN:T16D4 US: T16D4-21 DS: T16D4-20 RISK: 13 DIA: 8 MAT: VCP-Vetrified Clay Pipe	HYDRO YR: 2012	
Hydro Freq Yrs: 2		Tot Len: 1,327.27	
ID: 594	BASIN:T16D4 US: T16D4-3 DS: T16D4-2 RISK: 10 DIA: 8 MAT: VCP	HYDRO YR: 2012	
ID: 1684	BASIN:T16D4 US: T16D1-1 DS: T16D4-23 RISK: 8 DIA: 8 MAT: VCP	HYDRO YR: 2012	
Hydro Freq Yrs: 3		Tot Len: 435.64	
Basin: T16D4	Tot Len: 1,981.43		

Hydro Cleaning Schedule

OUTPUT

Hydro
Cleaning
Schedule

CCTV
Inspection
Schedule

Data Integrity
For pipe
specifications

Preventative
& Corrective
Work Orders

Replacement
Costs

CIP Projects

Performance
Metrics

Web Based
CMMS
Application

Web Based
GIS
Application

Crystal
Reports

Critical
Assets

Hydro Cleaning / CCTV Schedule Weighted Factors

CCTV Observations (PACP)
Grease Observations (From hydro-cleaning work)
Risk
Probability of Failure
Overflow Occurrence
Date of Last Cleaning or CCTV
Pipe Age

OUTPUT



HYDRO-CLEANING FREQUENCY

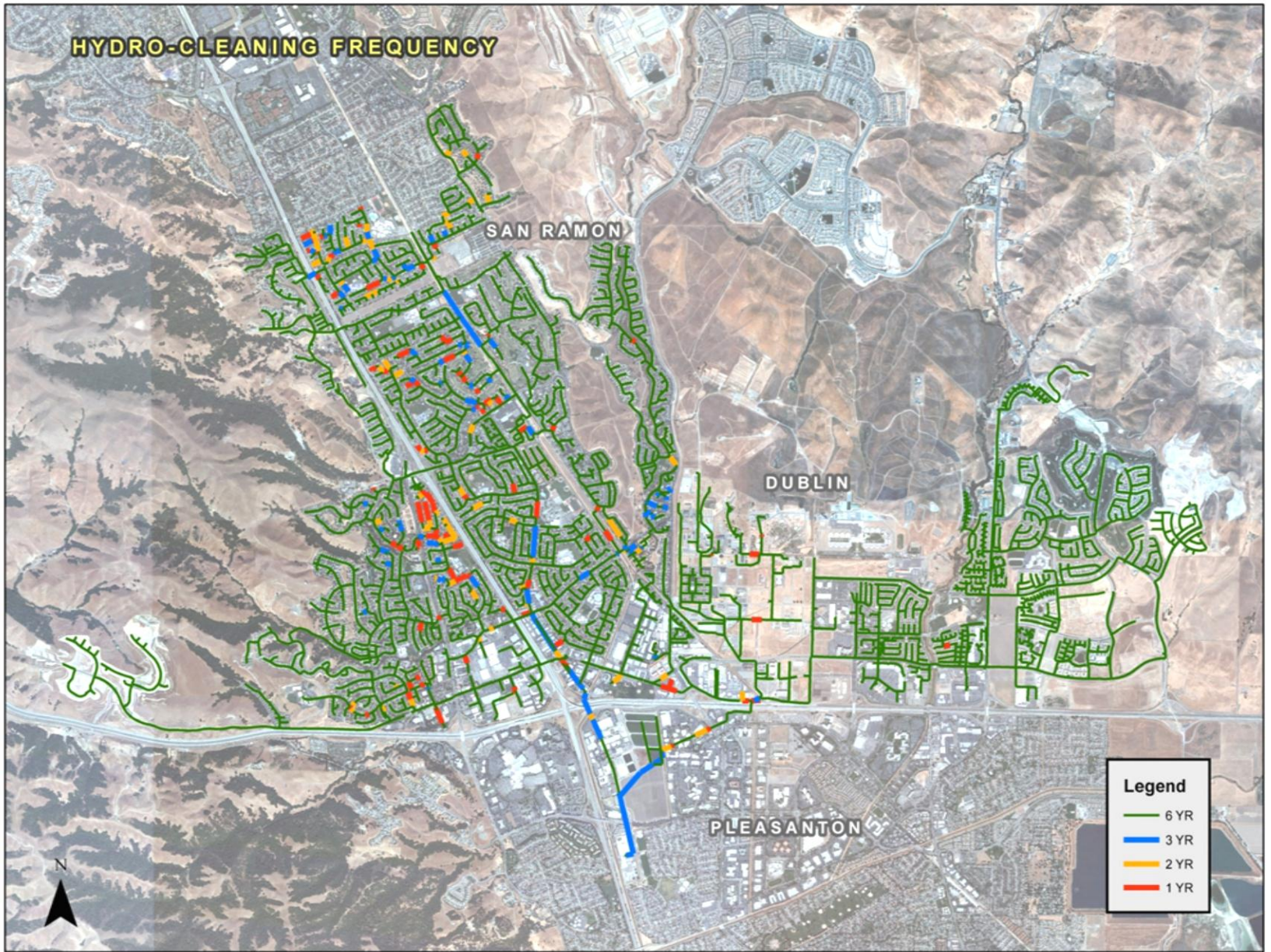

Legend

- 6 YR
- 3 YR
- 2 YR
- 1 YR



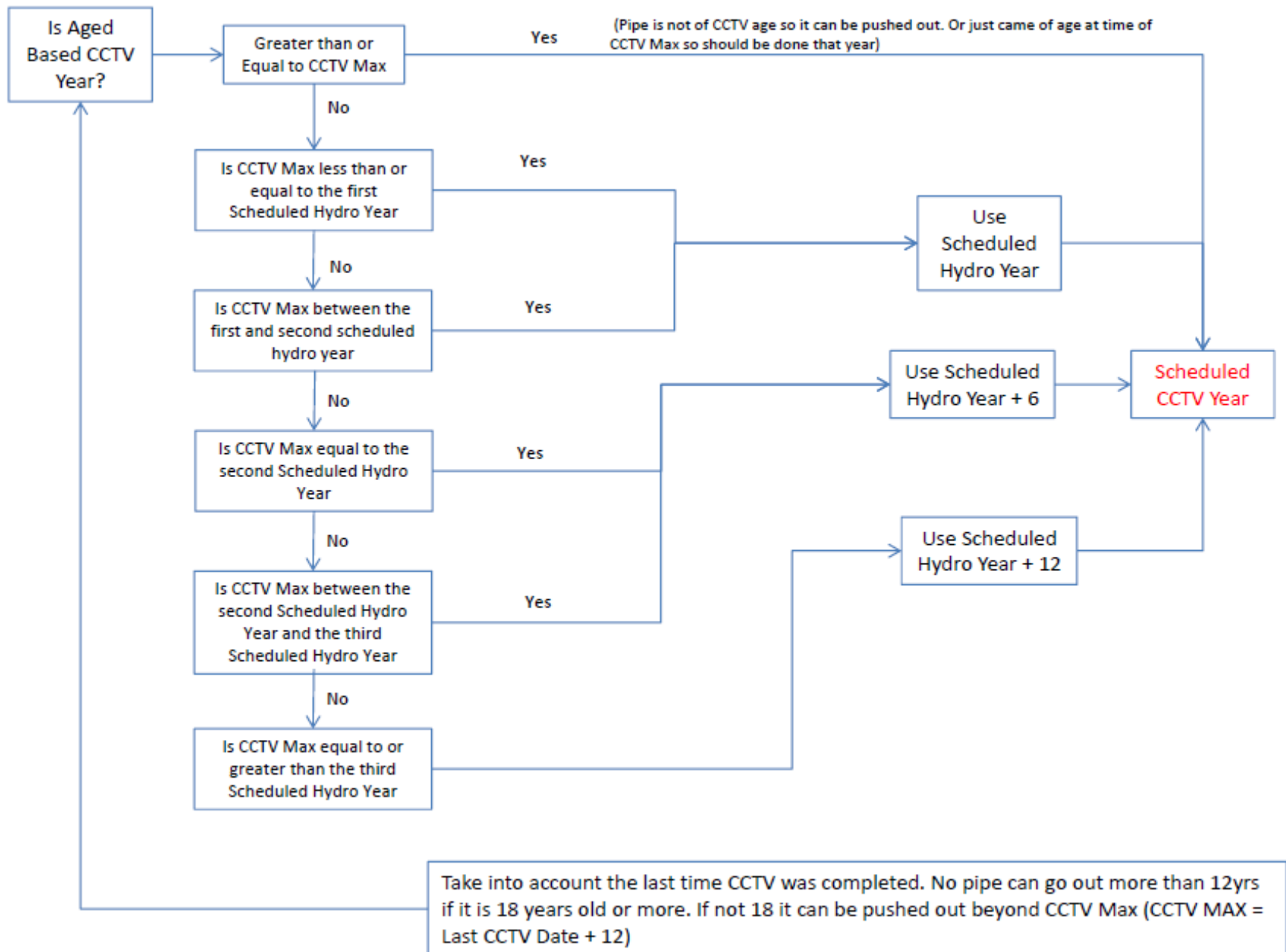

T2001-MH30
4/6/2011

ROOT PR

7/6/2011 10:56:37AM

Hydro Cleaning 6 Year Overview
Dublin San Ramon Services District

Page: 1

Year Sequence	Calendar Year	Recurring Feet	Budget	Total Feet	% of Total
1	2012	0		250,321	25%
2	2013	23,739	274,831	298,570	30%
3	2014	23,739	165,365	189,104	19%
4	2015	40,973	187,313	228,286	23%
5	2016	23,739	28,742	52,481	5%
6	2017	67,770	76,955	144,725	15%

Budget

Complete Hydro by Pri %

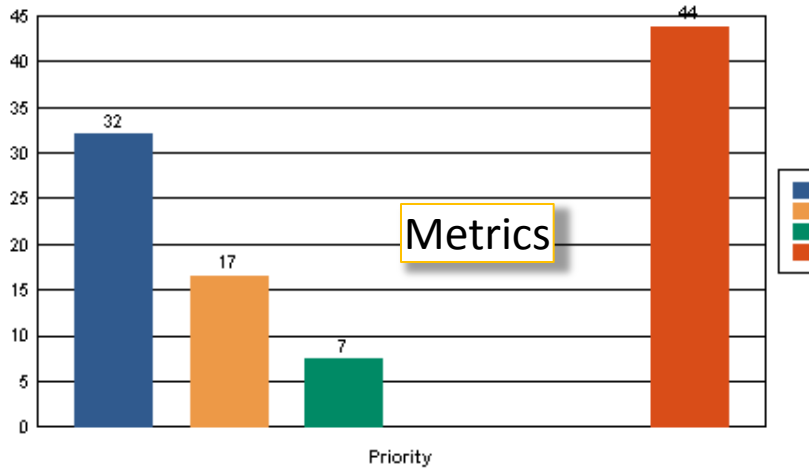

Metrics

Chart of Total Feet by Year

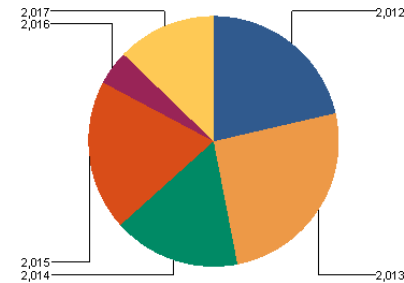

OUTPUT

Hydro Cleaning Schedule	CCTV Inspection Schedule	Data Integrity For pipe specifications	Preventative & Corrective Work Orders	Replacement Costs	CIP Projects	Performance Metrics
	Web Based CMMS Application	Web Based GIS Application	Crystal Reports	Critical Assets		

Completed Hydro 2013 Summary

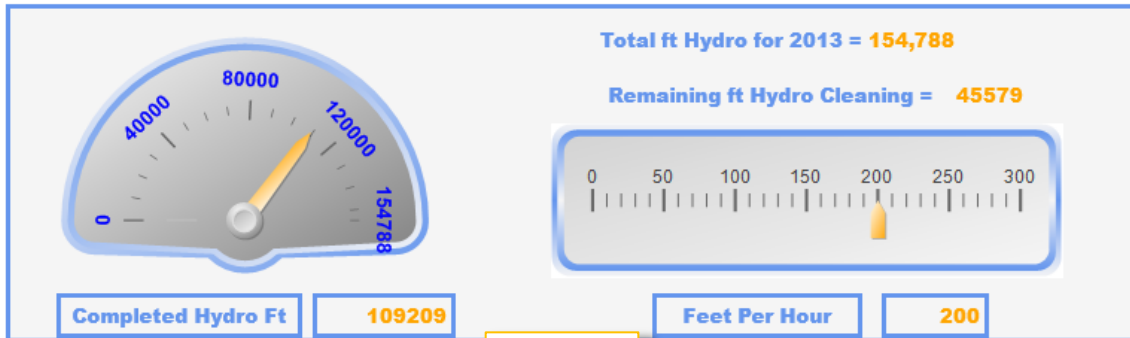

Metrics

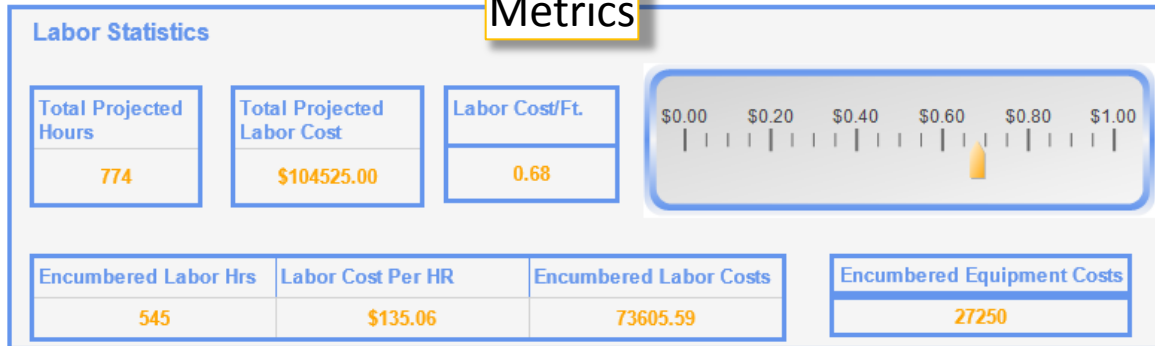

OUTPUT

Hydro Cleaning Schedule	CCTV Inspection Schedule	Data Integrity For pipe specifications	Preventative & Corrective Work Orders	Replacement Costs	CIP Projects	Performance Metrics
Web Based CMMS Application	Web Based GIS Application	Crystal Reports	Critical Assets	SQL SERVER Reporting Services		

T2001-MH00
4/6/2011

TO
ROOT PROBLEMS

T2001-MH00
14:01

Collections System Asset Management Project

Provide Finance with
Replacement Funding
Estimates

FT 212.7

T2001-MH00

TO

T2001-MH00

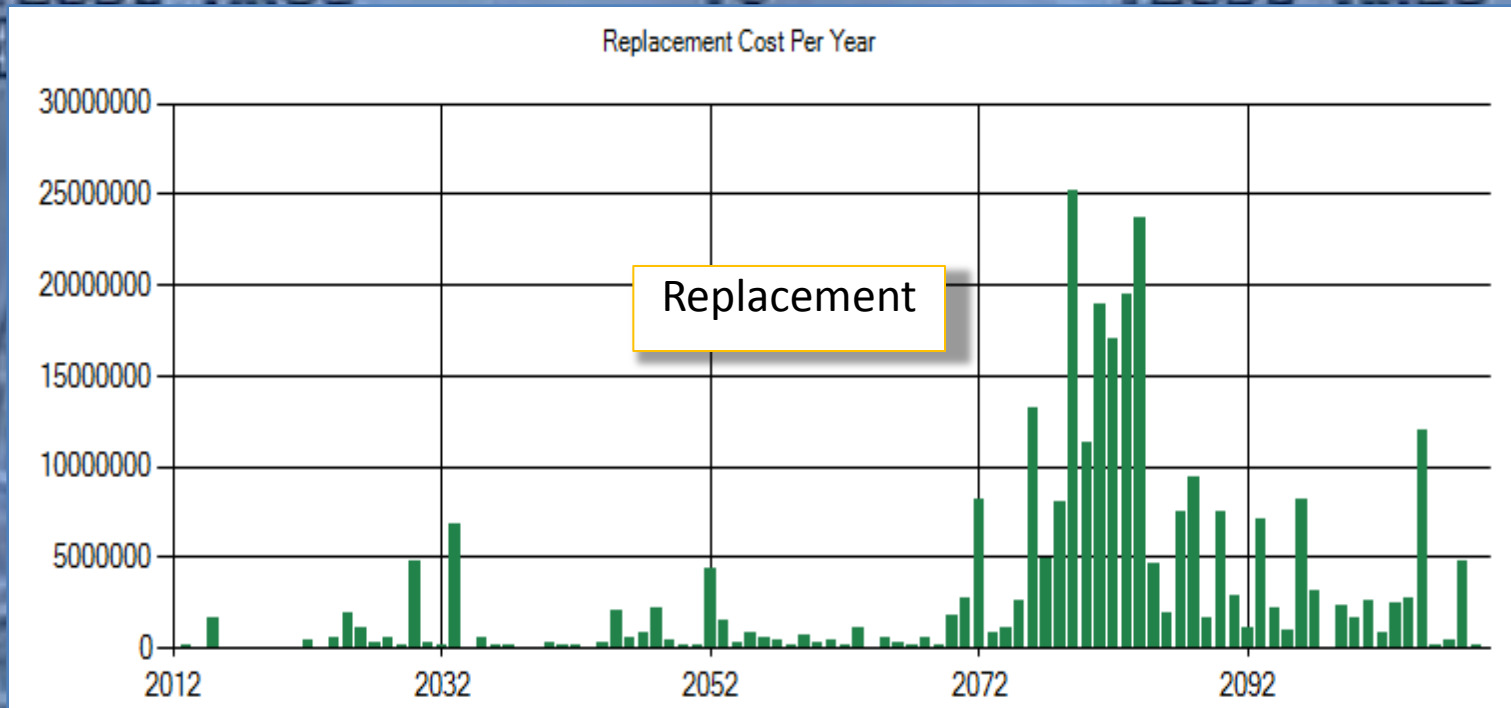

OUTPUT



T2001-MH00
4/6/2011

TO
ROOT PROBLEMS

T2001-MH00
14:01

Collections System

Asset Management Project

Provide Engineering
with project
identification

FT 212.7

T2001-MH30

UpstreamMH	DownstreamMH	Diameter	Material	Length	Highest Condition Rating	Install Date	
V17C1-32	V17C1-31	8	PVC	161.4	5	1991	2
V19A2-6	V19A2-5	10	PVC	382.6	5	1985	2
U17C3-11	U17C3-8	8	VCP-Vetrified Clay Pipe	272.2	5	1972	4
U18D2-5	U18D2-3	8	VCP	372.9	5	1964	4
V19A1-23	V19A1-22	8	VCP-Vetrified Clay Pipe	249.2	5	1965	4
T18D1-21	T18D1-20	8	VCP-Vetrified Clay Pipe	83.1	5		
U20C1-30	U20C1-29	8	VCP-Vetrified Clay Pipe	161	5	1981	4
T16D1-19	T16D1-18	6	VCP-Vetrified Clay Pipe	108.6	5	1969	4
T20D1-1	U20C2-14	8	VCP-Vetrified Clay Pipe	284.9	5	1965	4
U20C1-18	U20C1-17	8	VCP-Vetrified	167.6	5	1981	4

Critical



OUTPUT



Engineering

- Hydro Cleaning 6 Year Overview Report
- Hydro Cleaning Schedule Report
- Hydro Cleaning Complete / Incomplete
- Hydro Cleaning Reports User Manual
- Collection System Critical Asset Information

Submitted Work Request (0)

Collection System PACP Inspection O&M Defects

- > Root Observations Greater than 2 (32)
- Joint Observations (46)
- Lateral Observations (20)
- Grease Observations (6)

Lucity WEB

Collection System PACP Structural Defects

- Sag Observations (6)
- Offset Joint Observations (9)
- Crack Observations (8)

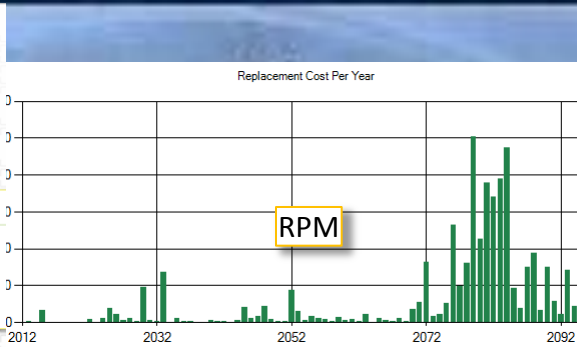

Hydro Cleaning 6 Year Overview
Dublin San Ramon Services District

Year Sequence	Calendar Year	Recurring Feet	Onetime Feet	Total Feet	% of Total
1	2012	0	250,321	250,321	25%
2	2013	23,739	274,831	298,570	30%
3	2014	23,739	165,365	189,104	19%
4	2015	40,973	187,313	228,286	23%
5	2016		28,742	52,481	5%
6	2017		76,955	144,725	15%

Budget

Chart of Total Feet by Year

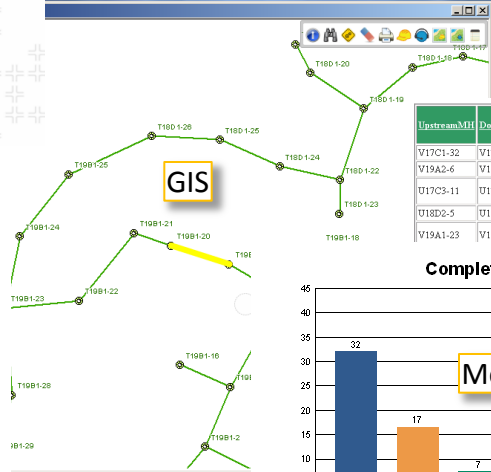
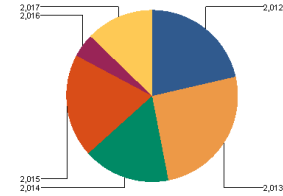

UpstreamMH	DownstreamMH	Diameter	Material	Length	Highest Condition Rating	Install Date	Effective Remaining Life (yrs)	Replacement Date	Replacement Value	POF	COF	Risk
V17C1-32	V17C1-31	8	PVC	161.4	5	1991	2	2013	40203.7500	0.96	17	16.32
V19A2-6	V19A2-5	10	PVC	382.6	5	1985	2	2013	115567.8200	0.96	25	24
U17C3-11	U17C3-8	8	VCP-Verified Clay Pipe	272.2	5	1972	4	2015	67791.1200	0.96	21	20.16
U18D2-5	U18D2-3	8	VCP	372.9	5	1965		2015	92866.5300	0.96	21	20.16
V19A1-23	V19A1-22	8	VCP-Verified Clay Pipe	249.2	5	1965		2015	62069.9500	0.96	21	20.16
								2015	20706.2300	0.96	17	16.32
								2015	40111.9400	0.96	17	16.32

CIP

Year: 2012
7/6/2011 11:06:00AM Hydro Cleaning Schedule
Dublin San Ramon Services District Page: 3

Hydro Freq Yrs:	Tot Len:
2	188.12

ID	Basin	T16D3	US	T16D3-3	DS	T16D3-2	RISK	9	DIA	8	MAT	VCP-Verified Clay Pipe	HYDRO YR	2012
350	BASIN-T16D3	US	T16D3-3	DS	T16D3-2	RISK	9	DIA	8	MAT	VCP-Verified Clay Pipe	HYDRO YR	2012	
344	BASIN-T16D3	US	T16D3-13	DS	T16D3-7	RISK	8	DIA	8	MAT	VCP-Verified Clay Pipe	HYDRO YR	2012	
1690	BASIN-T16D3	US	T16D3-2	DS	T16D3-1	RISK	15	DIA	15	MAT	VCP-Verified Clay Pipe	HYDRO YR	2012	
1694	BASIN-T16D3	US	T16D3-15	DS	T16D3-14	RISK	8	DIA	8	MAT	VCP-Verified Clay Pipe	HYDRO YR	2012	
2927	BASIN-T16D3	US	T16D4-1	DS	T16D3-9	RISK	11	DIA	10	MAT	VCP-Verified Clay Pipe	HYDRO YR	2012	

Basin: T16D3 Tot Len: 1,878.26

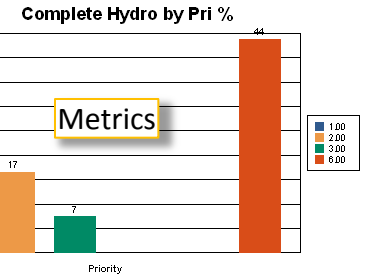

Hydro Cleaning Schedule

Hydro Freq Yrs:	Tot Len:
1	1,174.40

ID	Basin	T16D4	US	T16D4-8	DS	T16D4-7	RISK	14	DIA	6	MAT	VCP	HYDRO YR	2012
1699	BASIN-T16D4	US	T16D4-8	DS	T16D4-7	RISK	14	DIA	6	MAT	VCP	HYDRO YR	2012	
1595	BASIN-T16D4	US	T16D4-15	DS	T16D4-2	RISK	13	DIA	8	MAT	VCP	HYDRO YR	2012	
1701	BASIN-T16D4	US	T16D4-15	DS	T16D4-2	RISK	13	DIA	8	MAT	VCP	HYDRO YR	2012	
1697	BASIN-T16D4	US	T16D4-2	DS	T16D4-1	RISK	13	DIA	8	MAT	VCP-Verified Clay Pipe	HYDRO YR	2012	
1698	BASIN-T16D4	US	T16D4-4	DS	T16D4-3	RISK	13	DIA	8	MAT	VCP	HYDRO YR	2012	
590	BASIN-T16D4	US	T16D4-21	DS	T16D4-20	RISK	13	DIA	8	MAT	VCP-Verified Clay Pipe	HYDRO YR	2012	

Hydro Freq Yrs: 2 Tot Len: 1,327.27



OUTPUT

Hydro Cleaning Schedule	CCTV Inspection Schedule	Data Integrity For pipe specifications	Preventative & Corrective Work Orders	Replacement Costs	CIP Projects	Performance Metrics
Web Based CMMS Application	Web Based GIS Application	Crystal Reports	Critical Assets			

INPUT



STORAGE



OUTPUT



T2001-MH00
4/6/2011

TO
ROOT PROBLEMS

T2001-MH00
14:01

A look back

- Prevented SSO on Day Two
- Creating more corrective work orders to remove roots
- Difficult to push hardware out to field crew (Not using Lucy in the field yet)
- Finding and correcting data inaccuracy in both Lucy DB and GIS
- Work order management is critical for success
- Field Ops is generating its own work orders and using the system with little help
- Opened the door to using Lucy for other tasks

FT 212.7

T2001-MH00
4/6/2011

TO
ROOT PROBLEMS

T2001-MH00
14:01

Questions?

FT 212.7



Quiz Answers

- NASSCO

[NASSCO National Association of Sewer Service Companies](#)

www.nassco.org/ ▼

NASSCO - Setting the Industry Standards for the Rehabilitation of Underground Utilities. ... [NASSCO Facebook Page](#) [NASSCO YouTube Channel](#). [My Account](#) | ...

[PACP - PACP Class Schedules](#) - [Contact Us](#) - [Login](#)

- PACP

Training & Recertification

Pipeline Assessment & Certification Program

Current Version- 6.0.1 Released November 2010

Intro

- Don Kurtz
- IT Analyst
- Dublin San Ramon Services District
- kurtz@dsrsd.com

PipeDream Database Secrets

- GBASewer database tables and columns describe collection system

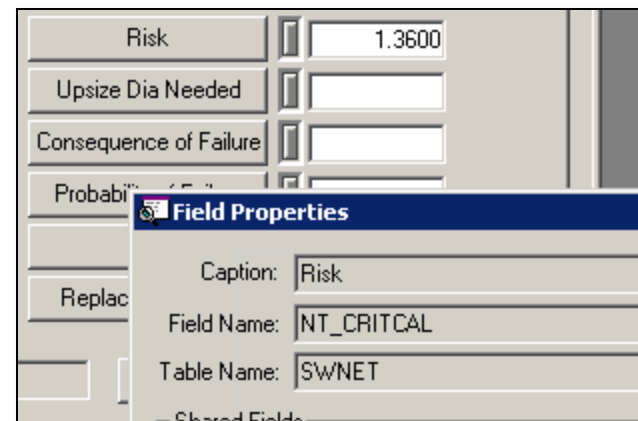
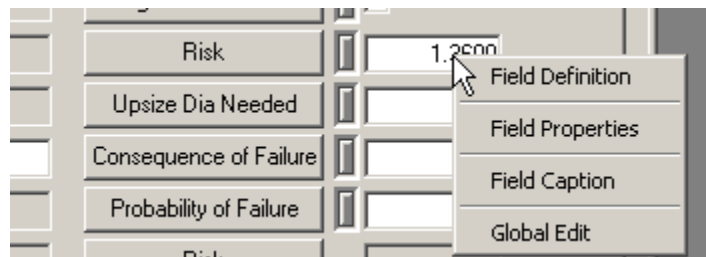

- SQL Agent recalculates all values for each pipe segment each night (5000 segments in 48 sec)

The 3 BIG Questions

- How often should I clean this pipe segment?
- When was this segment last cleaned?
- When is the next time that this pipe segment should be cleaned?

How often should I clean segment?

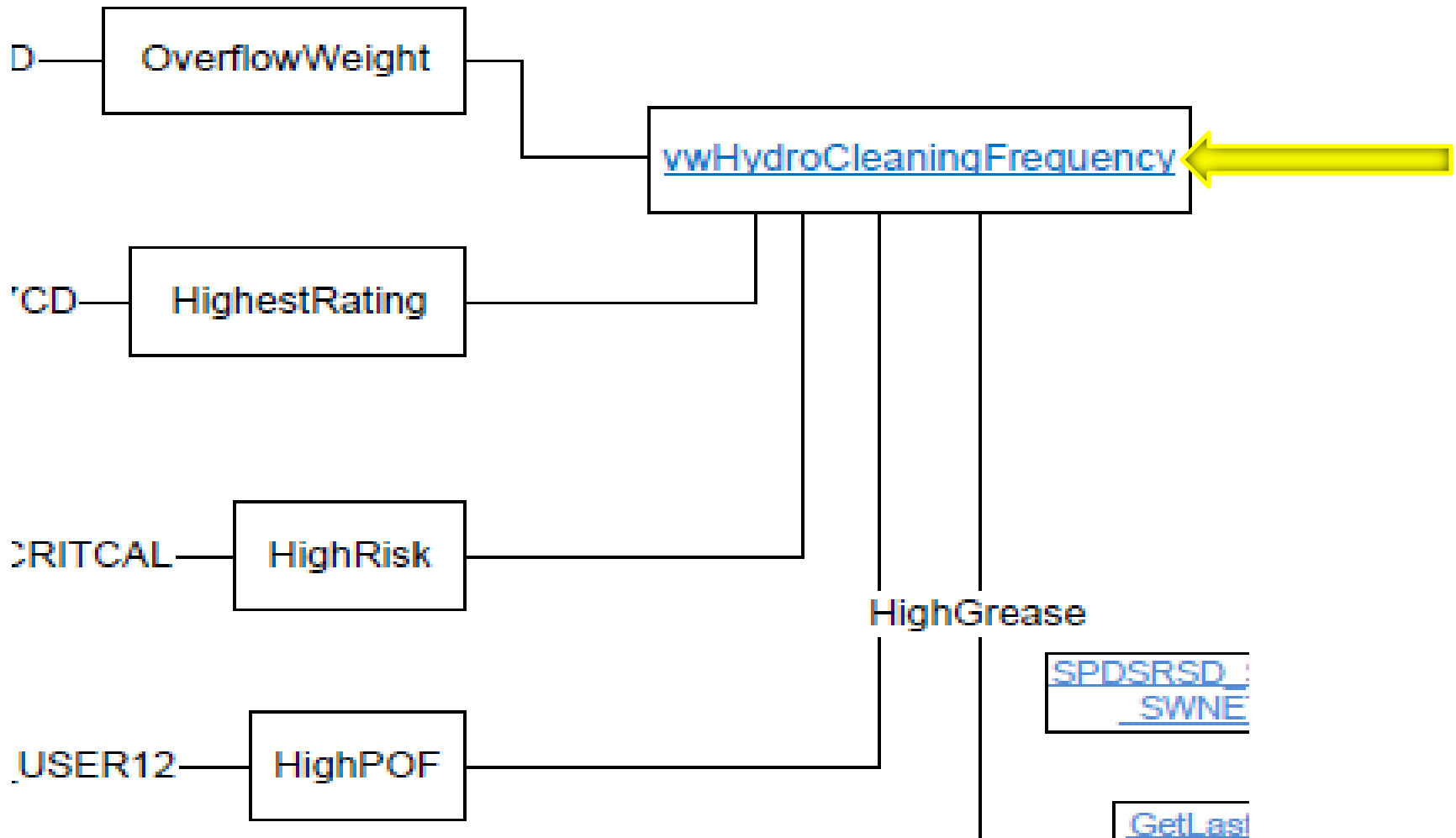

When was segment last touched?

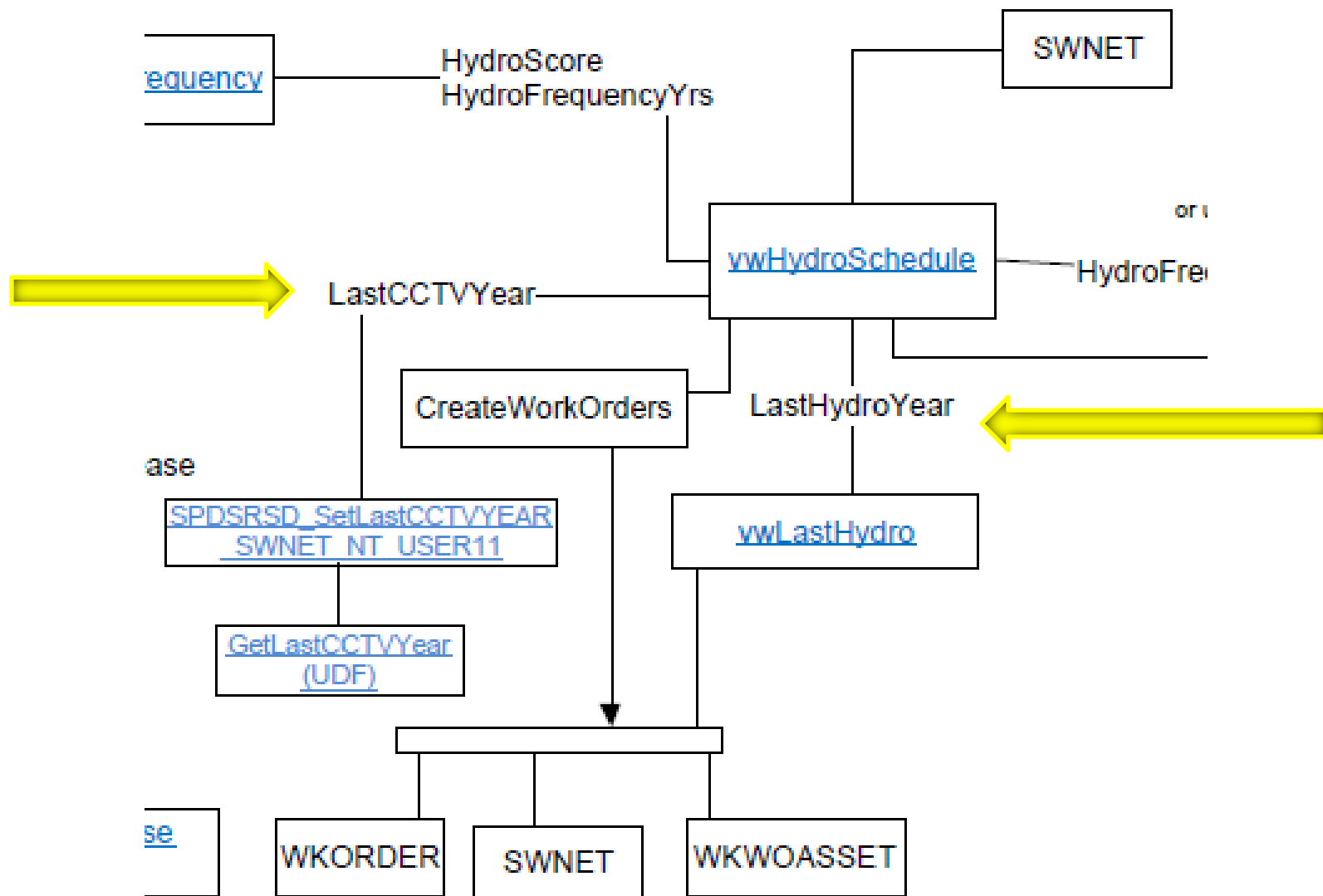

When is the next cleaning?

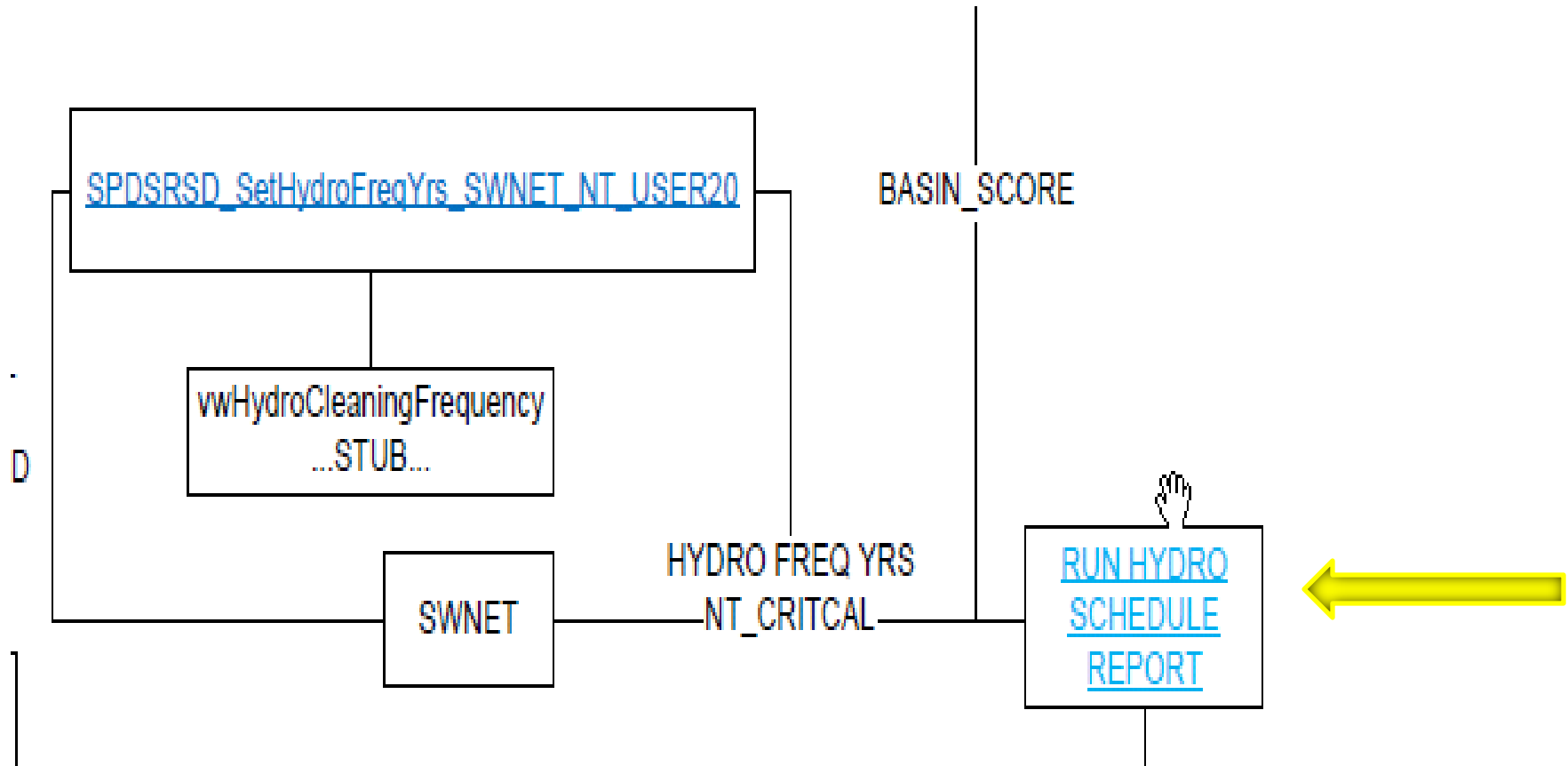

Basin Scoring

- Basin score based on worst-quality segment in the basin

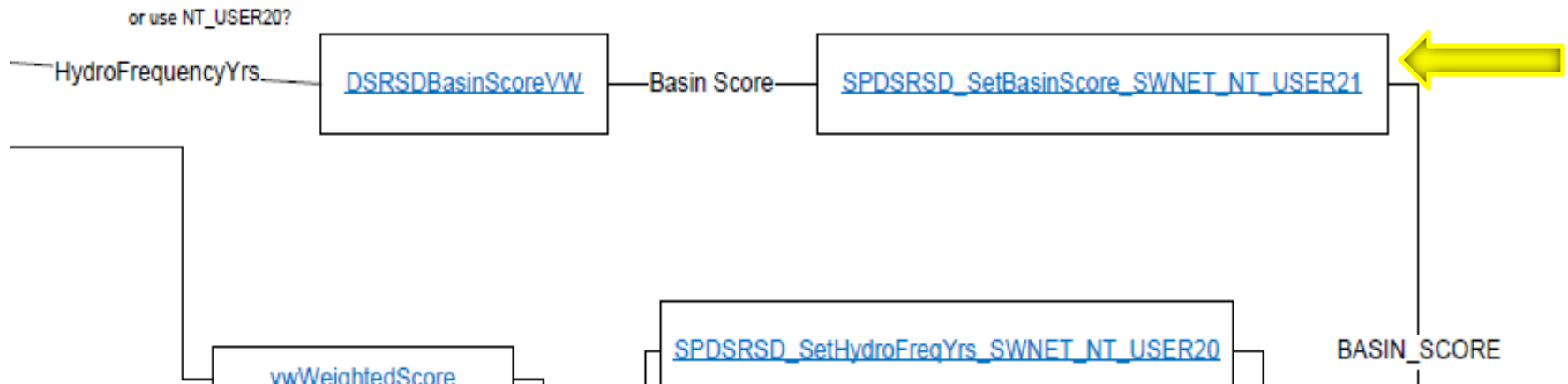

Nightly data update hierarchy

- exec SPDSRSD_CleanUpMHInspGPSData
- exec SPDSRSD_INSERTMHInspGPSSWMAN
- exec SPDSRSD_SetLastCCTVYEAR_SWNET_NT_USER11
- exec SPDSRSD_SetScheduledCCTVYear_SWNET_NT_USER10
- exec SPDSRSD_SetHighestPACPRating_SWNET_NT_USER17CD
- update swnet set NT_USER17CD = isnull (NT_USER17CD,0)
- exec SPDSRSD_SetReplacementValue_SWNET_NT_RVALUE
- exec SPDSRSD_SetPOF_SWNET_NT_USER12
- exec SPDSRSD_SetCOF_SWNET_NT_USER4
- exec SPDSRSD_SetHighRisk_SWNET_NT_CRITCAL
- exec SPDSRSD_SetHydroFreqYrs_SWNET_NT_USER20
- exec SPDSRSD_SetBasinScore_SWNET_NT_USER21
- exec SPDSRSD_SetHydroYear_SWNET_NT_USER9
- exec SPDSRSD_SetReplacementDate_SWNET_NT_REPL_DT
- Exec SPDSRSD_SetHydroScore_SWNET_NT_USER13

Calculation engine hierarchy

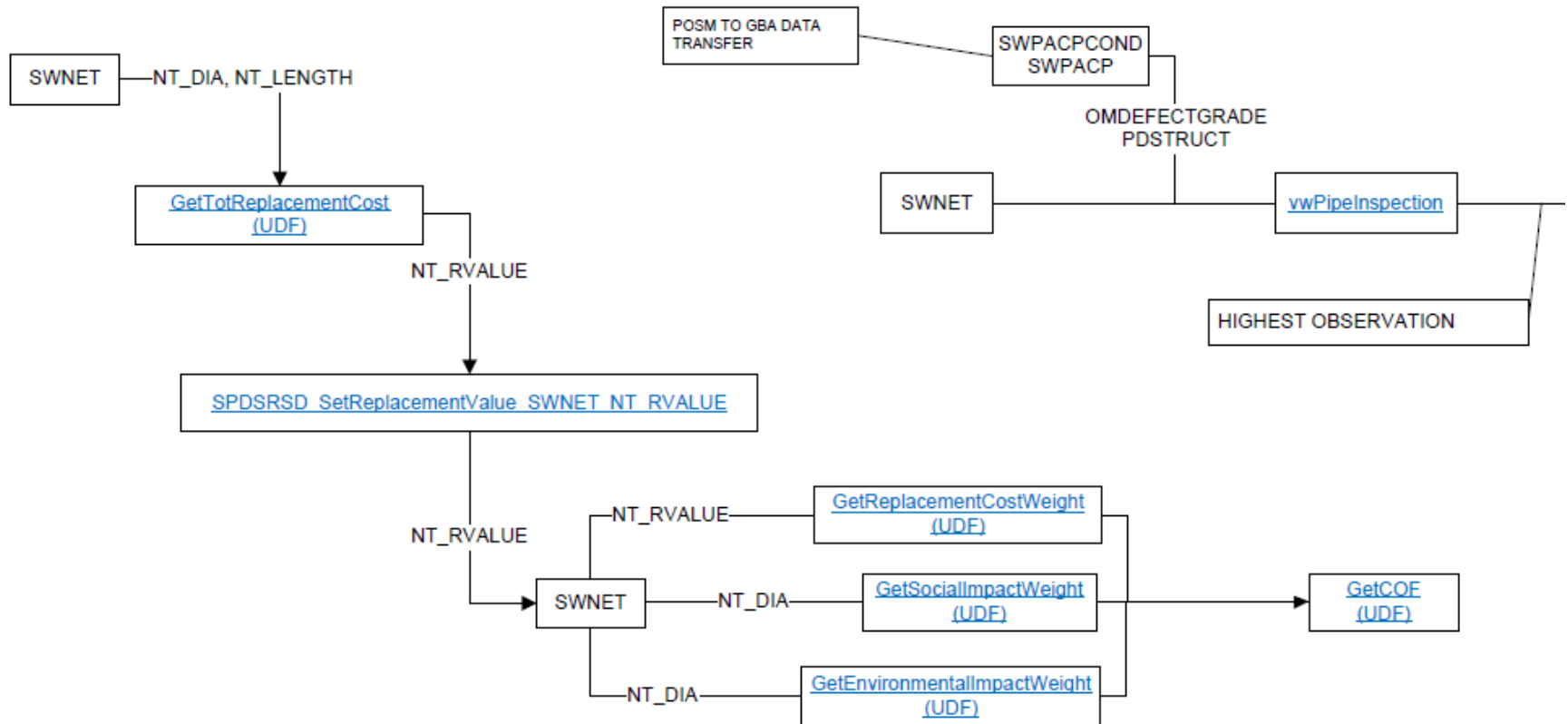

Lucidity client user interface 1

System General Environmental Sewer Storm Transportation water Electric Gas Trees/Parks Equipment Facility Reuse/Recycling work Inventory Mobile view window

Sewer Pipe Inventory - No Filter

Pipe Rec # 1836 US Structure T20D2-14 7440 AMARILLO RD Next US
Alt Pipe ID NTG_1422 DS Structure T20D2-13 7416 AMARILLO RD Next DS

Attributes Construct Elevations FM TV PACP Lamping Smoke Bldg Insp Laterals Overflows Acceptance Rehab WD/PM/Req Instruct Custom Col

Status	<input type="checkbox"/>	Map Page No.		Review Comments	<input type="checkbox"/>	Active	<input type="checkbox"/>
Collected By		Length (ft)	139.1				
Flow Basin	T20D2	Length Status	6 Hansen Data				
Owner	2 Dublin San Ramon	Pipe Sec Length (ft)	5.0	Est # of Joints			
Location		Material	1 VCP-Vitrified Clay Pipe				
Line Type	1 Gravity Line	Liner					
Flow Type	1 Sanitary	Lining Date	/ /	Year Lined			
Pipe Shape	1 Round	Slope %	1.000	<input type="checkbox"/> Slope Lock			
Cleaning Freq		Mannings					
TV Frequency		Capacity (cfs)	0.00				
Dia/Height (in)	8	IDM					
Pipe Width (in)		Pump Station ID					
Managed By		Last Cleaning Date	/ /	Cleaning Freq			
Fixed Asset ID		Next Cleaning Date	/ /	Cleaning Freq Units			

Lucidity client user interface 2

Lucidity 7.5 - Dublin San Ramon Services District

System General Environmental Sewer Storm Transportation Water Electric Gas Trees/Parks Equipment Facility Refuse/Recycling Work Inventory Mobile View Window

Sewer Pipe Inventory - No Filter

Pipe Rec # 1836 US Structure T20D2-14 7440 AMARILLO RD Next US
 Alt Pipe ID NTG_1422 DS Structure T20D2-13 7416 AMARILLO RD Next DS

Attributes Construct Elevations FM TV PACP Lamping Smoke Bldg Insp Laterals Overflows Acceptance Rehab WD/PM/Req Instruct Custom Coi

Date Constructed	07/20/1965	Cleaning Area		Ignore in Model	<input type="checkbox"/>
Project Number		Benefit District		Risk	8.1600
Index		Area	1 Dublin	Upsize Dia Needed	
US Station		Sec-Twn-Rng		Consequence of Failure	
DS Station		Trap Area		Probability of Failure	
Surface	1 Asphalt Street	Improve Method		Risk	
Bedding		Upstream Count		Replacement Cost	

Replacement Value 34629.04 Replacement Date 01/01/2064 Present Value Remaining Life

Construction Records

Start Date	Present Value	Remaining Life	Asset Cost	Salvage Value	Replace Previous Worth	No Remaining Value
------------	---------------	----------------	------------	---------------	------------------------	--------------------

Lucidity client user interface 3

System General Environmental Sewer Storm Transportation Water Electric Gas Trees/Parks Equipment Facility Refuse/Recycling Work Inventory Mobile View V

Sewer Pipe Inventory - No Filter

Attributes Construct Elevations FM TV **PACP** Lamping Smoke Bldg Insp Laterals Overflows Acceptance Rehab WO/PM/Req Instruct Custom Co

Upstream to Downstream - Most Recent Inspection

US Last PACP Date	05/02/2011
US Quick Structural	2100
US Quick O&M	0000
US Quick Total	2100

Downstream to Upstream - Most Recent Inspection

DS Last PACP Date	05/02/2011		
DS Quick Structural	0000	DS Pipe Structural	0.0
DS Quick O&M	0000	DS Pipe O&M	0.0
DS Quick Total	0000	DS Pipe Total	0.0

Inspected Date	Survey Direction Text	Quick Rating Structural	Quick Rating O&M	Quick Rating Total	Pipe Ratings Struct
05/02/2011	Downstream	2100	0000	2100	

Lucidity client user interface 4

Sewer Pipe Inventory - No Filter

Pipe Rec # US Structure 7440 AMARILLO RD

Alt Pipe ID DS Structure 7416 AMARILLO RD

Attributes Construct Elevations FM TV PACP Lamping Smoke Bldg Insp Laterals Overflows Acceptance Rehab WO/PM/Req Instruct Custom Col

Default WO Cat Collection Mains PM No WO/PM/Req

Work Orders

WO #	Main Task	Problem	Status	Status Date	End Date	Start Date	Completion Date
11-0041	HYDRO CLEANING		Complete	07/19/2011	02/17/2011	02/14/2011	02/15/2011
11-0032	CCTV INSPECTIONS		Complete	07/14/2011	05/02/2011	03/02/2011	05/02/2011
07-0336	HYDRO CLEANING		Complete	03/29/2007	03/27/2007	03/21/2007	03/22/2007
03-0096	CCTV INSPECTIONS		Complete		09/19/2003	09/15/2003	
03-0098	HYDRO CLEANING		Complete		09/05/2003	09/03/2003	

PMs

Code	Routine Text	Status	WO #	Next By Start	Next by End
2052	T20D2 CCTV	Awaiting WO Generation			
2053	T20D2 HYDROCLEAN	Awaiting WO Generation		05/01/2010	
2296	PRIORITY SEGMENT CCTV				

Requests

Status Date	Status	Request #	Problem	Cause	Name 1	Name 2	Business
-------------	--------	-----------	---------	-------	--------	--------	----------

Lucidity client user interface 5

System General Environmental Sewer Storm Transportation Water Electric Gas Pumps/Engs Equipment Facility Recycling/Recycling Work Inventory Mobile View Window

Sewer Pipe Inventory - No Filter

1836
 First 2-14
 AMARILLO RD

NTG_1422
 T20D2-13
 AMARILLO RD

User 1	<input type="checkbox"/>	<input type="text"/>	Con of Failure	<input type="checkbox"/>	<input type="text" value="17.00"/>	Not Accepted	<input type="checkbox"/>
Tap Rating	<input type="checkbox"/>	<input type="text"/>	Prob of Failure	<input type="checkbox"/>	<input type="text" value="0.48"/>	LOW FLUSH	<input type="checkbox"/>
Repair Rating	<input type="checkbox"/>	<input type="text"/>	Hydro Score	<input type="checkbox"/>	<input type="text" value="2.00"/>	PACP	<input checked="" type="checkbox"/>
User 16	<input type="checkbox"/>	<input type="text"/>	HydroFreqYrs	<input type="checkbox"/>	<input type="text" value="3.00"/>	POSMDVD	<input type="checkbox"/>
OM Cond Rtnng	<input type="checkbox"/>	<input type="text" value="2"/> <input type="text" value="2"/>	BasinScore	<input type="checkbox"/>	<input type="text" value="1.00"/>	GBACCTV	<input checked="" type="checkbox"/>
User 5	<input type="checkbox"/>	<input type="text"/>	ScheduledHydro	<input type="checkbox"/>	<input type="text" value="01/01/2014"/>	User 22	<input type="text" value="/"/>
User 14	<input type="checkbox"/>	<input type="text"/>	ScheduledCCTV	<input type="checkbox"/>	<input type="text" value="01/01/2014"/>	User 23	<input type="text" value="/"/>
User 15	<input type="checkbox"/>	<input type="text"/>	LastCCTV	<input type="checkbox"/>	<input type="text" value="01/01/2011"/>		
Avg Useful Life	<input type="checkbox"/>	<input type="text"/>	User 26	<input type="checkbox"/>	<input type="text"/>		
User 19	<input type="checkbox"/>	<input type="text"/>	User 27	<input type="checkbox"/>	<input type="text"/>		
Short Comment	<input type="checkbox"/>	<input type="text"/>					

Record 1680 of 5529 View Mode Ready...

Anyone for TSQL?

Sample function

- CREATE FUNCTION [dbo].[GetTotReplacementCost] (@NT_Length float, @NT_Dia float)
- RETURNS float
- WITH EXECUTE AS CALLER
- AS
- BEGIN
- declare @Tempvalue float;
- Select @Tempvalue =
- case
-
- when @NT_dia < 7 then (@NT_length * 195)
- when @NT_dia = 8 then (@NT_length * 249)
- when @NT_dia = 10 then (@NT_length * 302)
- when @NT_dia = 12 then (@NT_length * 356)
- when @NT_dia = 15 then (@NT_length * 436)
- when @NT_dia = 18 then (@NT_length * 517)

Sample linked server

- CREATE PROCEDURE [dbo].[SPDSRSD_CleanUpMHInspGPSData]
- -- Add the parameters for the stored procedure here
- update a
- set a.MAG_MANHOL = REPLACE(a.MAG_MANHOL,'=','-')
- from [ENGINEERING\SQLEXPRESS].[GBAGIS].[dbo].[MANHOLE_INSP_MERGE] a;
-
- delete from
- [ENGINEERING\SQLEXPRESS].[GBAGIS].[dbo].[MANHOLE_INSP_MERGE]
- where MAG_MANHOL is null
- or MAG_MANHOL = '-'
- or len(MAG_MANHOL) = 0

Sample stored procedure

- CREATE PROCEDURE [dbo].[SPDSRSD_SetLastCCTVYEAR_SWNET_NT_USER11]
- AS
- BEGIN
- SET NOCOUNT ON;
- UPDATE SWNET
- SET NT_User11 =
- (SELECT CAST
- (
- CAST
- (
- **dbo.GetlastCCTVYear(NT_ID) as varchar(4)**
-)
- + '-01-01'
- as DATETIME
-)
-)
-)
- END

Sample view

- create View [dbo].[vwPipeInspection] as
- select
- c.PD_ID
- ,n.NT_ID
- ,c.PD_CODE_TY AS ObservationType
- , datepart(yyyy,p.PA_INSP_DT) as InspectionYear
- , datepart(mm,p.PA_INSP_DT) as InspectionMonth
- ,p.PA_DIR_TY as SurveyDirection
- ,p.PA_ADDRESS as Street
- ,p.PA_PRIOM as PipeOMRatingIndex
- ,p.PA_PRIT as PipeTotalRatingIndex
- ,n.NT_USMAN as UpStreamMH
- ,n.NT_RVALUE as ReplacementValue
- ,n.NT_SURF_TY as Surface
- from SWPACPCOND c, SWPACP p, SWNET n
- where c.PD_PA_ID = p.PA_ID
- and n.NT_ID = p.PA_NT_ID
-

Summary

- How often should I clean this pipe segment?
 - When was this segment last cleaned?
 - When is the next time that this pipe segment should be cleaned?
-
- Questions